



TENNESSEE COLLEGE
OF APPLIED TECHNOLOGY
— HARTSVILLE —

EMERGENCY PLAN

REVISED FEBRUARY 2012

EMERGENCY RESPONSE PROCEDURES

TENNESSEE COLLEGE OF APPLIED TECHNOLOGY HARTSVILLE - Main Campus –
716 McMURRY BLVD E, HARTSVILLE, TN
Extension Campus - 2575 NORTH SPRINGS RD, RED BOILING SPRINGS, TN
and supplemental to its instructional service centers:
WILSON COUNTY CAMPUS, LEBANON, TN

READ AND UNDERSTAND INSTRUCTIONS
THE LIFE YOU SAVE MAY BE YOUR OWN!

INTRODUCTION

Safety is everyone's responsibility. All of us must be alert to potential hazards and dangers. Emergencies and disasters are unpredictable and most often strike without warning. However, even the effect of natural disasters can be minimized by preparedness.

This health and safety plan contains quick reference information and guidelines on how to report an emergency, what to do, who will assist you, and what help will come from College personnel and professional emergency units during such emergencies.

CONDUCT

The following rules of personal conduct have been established to maintain a safe work environment for employees and students at the Tennessee College of Applied Technology Hartsville. Any employee or student violating any of the following rules may be subject to dismissal:

1. Consumption of alcohol or unauthorized drugs is strictly prohibited on campus.
2. Reckless operation of personal vehicles on campus will not be permitted.
3. Flagrant disrespect for campus property and safety of personnel and other students will not be permitted.
4. Any injury or suspected injury will be reported immediately to the instructor.
5. Horseplay will not be permitted.
6. Each employee and student will abide by the rules and recommendations described in the Safety Program.
7. Possession of firearms or weapons on TCAT Hartsville property will result in immediate expulsion and local law enforcement will be notified.

STUDENT RESPONSIBILITY

Students must assume responsibility for their safety and that of others. Student responsibilities are as follows:

1. Work within the bounds of school policies and safety regulations.
2. Develop desirable behavioral patterns and attitudes by accepting directions, advice and counsel.
3. Accept personal responsibility for assisting in the safety program and in working toward its success.
4. Ask questions concerning proper operation of tools and equipment.
5. Ask permission before operating any tools or equipment.
6. Inspect equipment and/or tools prior to each use.
7. Report any unsafe actions or condition to the instructor.

8. Utilize and wear personal protective equipment as required.

EVACUATION PROCEDURES

Generally, evacuation of a building occurs when the following happen: fires and threats of explosion. Training areas are evacuated for hazardous material releases.

When an evacuation of building is necessary, all individuals present shall immediately evacuate the building. An alarm or public address system announcement will notify you of the emergency. **ALWAYS** assume that the alarm is genuine. **ALWAYS** evacuate.

Emergency exit diagrams identifying location and evacuation routes are posted prominently in each area. Alternate routes are identified where possible or appropriate. Know evacuation routes from each area in which you may have some activity. Be aware of whether or not exits are clear and accessible. Find alternate routes.

Stay calm. Do not run, rush or panic. Persons evacuating shall evacuate in an orderly manner and report to the assembly area as soon as possible. Students are to remain together outside the building until roll is called, this process must occur quickly and in an orderly manner. Under no circumstances should persons evacuating the building be allowed to leave the premises until properly accounted for.

It is the responsibility of each student to know their emergency evacuation procedures for their area/building. The evacuation signal at the Hartsville campus and Extension Campus is an intermittent alarm tone or address by "Code" over the public address system. Instructional service centers will evacuate at the local administration's signal or TCAT Hartsville faculty and/or staff personnel's signal.

DO'S

1. Follow the instructions of your individual evacuation plan.
2. Close the door of your area as you leave.
3. Form an evacuation line – single line.
4. Use the nearest EXIT.
5. Keep talking to a minimum.
6. No smoking.
7. WHERE APPLICABLE: Use the handrails in enclosed stairwells.
8. Listen for instructions and follow them.
9. The method of evacuation of handicapped individuals shall be the "**Buddy System**".
10. Be ready to merge with other people evacuating the building.
11. Once out of the building, go to your designated primary or secondary assembly area.

DON'TS

1. WHERE APPLICABLE: Do not go to the elevators – they will not respond.
2. Once you have left your area, do not return for coat, purse and etc.
3. Do not run or create panic.
4. Do not return to the building until the “**ALL CLEAR**” is given by ADMINISTRATION or its designee.

STEP BY STEP INSTRUCTIONS

1. An evacuation may be necessary in the event of any occurrence which may threaten the safety of lives. Such occurrences may include, but are not limited to: fires, storms, gas leaks and drills.
2. Never assume when the alarm sounds that the evacuation is just another DRILL. Follow proper evacuation procedures immediately each time an alarm sounds.
3. Instructors are designated to ensure all persons in their training area are successfully evacuated and will assume the additional responsibility for escorting or assigning escort via the “**Buddy System**” of disabled individuals to safety.
4. Remain calm.
5. If time permits, disengage electrical equipment which you are currently using.
6. Leave all belongings in the classroom. There is no time to decide what to take with you.
7. If a closed door is extremely hot, do not open it. Seek another exit.
8. Immediately exit the classroom and building according to the posted route. (See the emergency exit diagram in your classroom/shop area.)
9. If you encounter a smoke-filled room or hallway, stay as close to the floor as possible to avoid noxious gases.
10. Upon exiting the building, go directly to the assembly area. Stay with your group. If the assembly area is inaccessible, proceed to the secondary assembly area.
11. During this time, remain quiet and calm. DO NOT SMOKE in case there is a gas leak.
12. Do not reenter the building until authorized by the “**All Clear**” notification from Administration or its designee.

Assembly Areas

1. Hartsville Campus: Northernmost parking area in front of facility as noted on emergency exit diagram.
2. Tri-County Extension Campus: Southernmost parking area in front of facility as noted on emergency exit diagram.
3. Trousdale County High School: Rear parking lot accessible from the Practical Nursing classroom as noted on emergency exit diagram.
4. Union High Resource Center: Front parking area accessible to Small Street as noted on emergency exit diagram.
5. Westmoreland Center: Playground area as noted on emergency exit diagram.
6. Wilson County Career and Technical Education Center: Rear parking area accessible to Tennessee Boulevard as noted on emergency exit diagram.

****In the event of inclement weather, provisions should be made to minimize exposure.**

FLOOR OR ELEVATOR EMERGENCY (WHERE APPLICABLE)

Elevators are one of the safest modes of transportation that there is; however, they do have malfunctions due to sophisticated automatic controls.

WHAT TO DO IN AN ELEVATOR EMERGENCY

1. Open door below floor selection button, press button on emergency, normally a monitoring system will respond; so, speak clearly about the situation.
2. Remain calm.
3. Do not force open the elevator door.
4. If the malfunction is observed from outside the elevator, notify building administration.

HERE IS WHAT HAPPENS:

1. Local administration will secure assistance.
2. Someone will communicate with you.
3. Passengers will be assisted as soon as possible.

TRAINING AND DRILLS

Evacuation drills are necessary for the safety of students; faculty and staff; and visitors. When the alarm sounds or signal is given for evacuation, everyone should know the specific directions for reaching a point of safety from those areas of the building in which he/she may be. This information is posted in each training area and office as an emergency exit diagram. Special instructions may be announced over the public address system.

1. Emergency evacuation drills are unannounced.
2. Evacuation routes are posted in all classroom/shop areas.
3. Students will follow designated exit instructions, will keep in single file and will walk (not run), will refrain from talking and will proceed to the designated assembly area.
4. The instructor will call roll once the group has reached the designated assembly area. For this reason, students must remain with their class after leaving the building. **There will be no smoking at this time.**
5. When the “**All Clear**” signal is given by Administration or its designee, all will return to their areas in an orderly fashion.

Tennessee College of Applied Technology Hartsville Emergency Exit Diagram

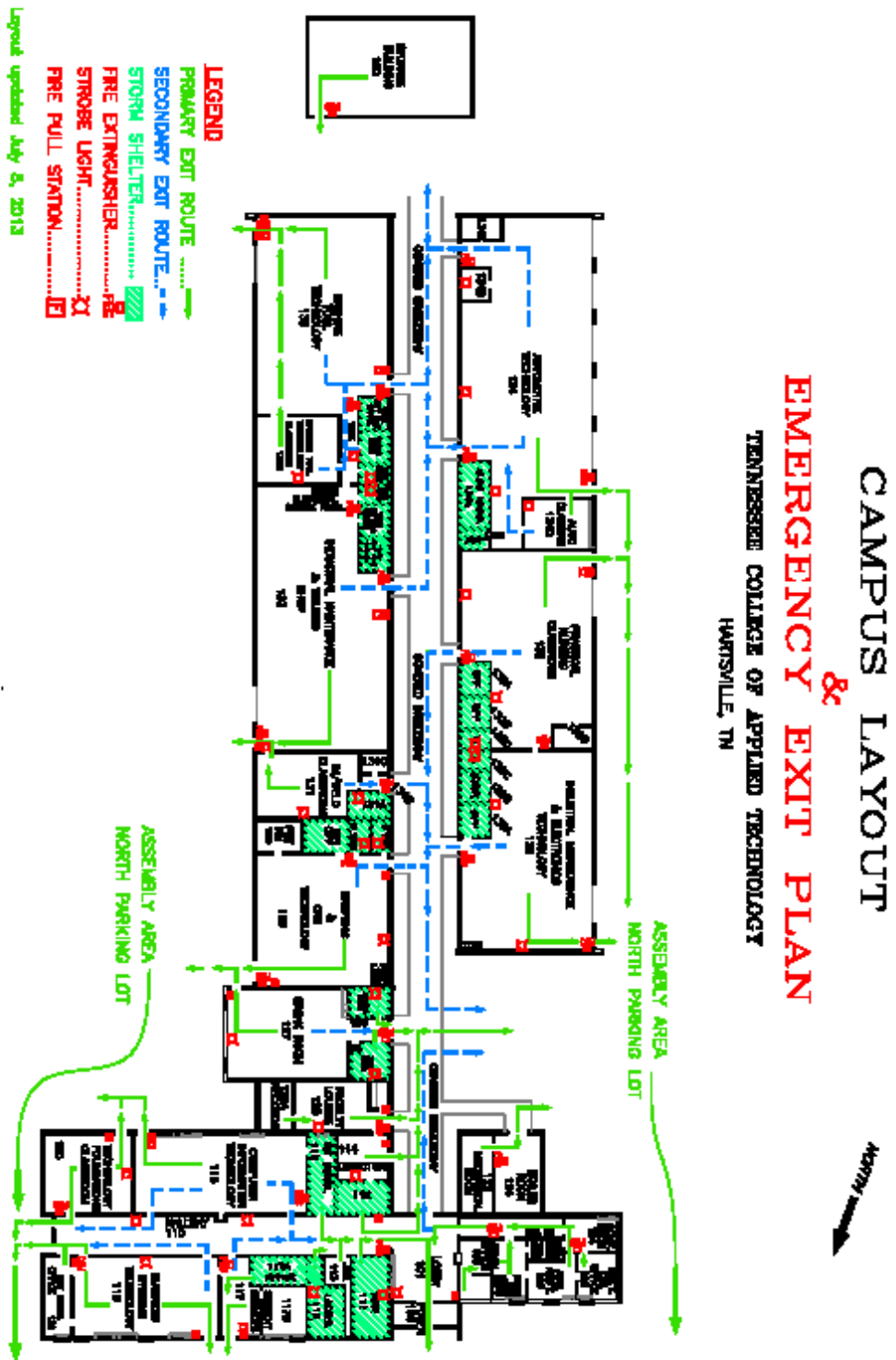

Tri-County Extension Campus Emergency Exit Diagram

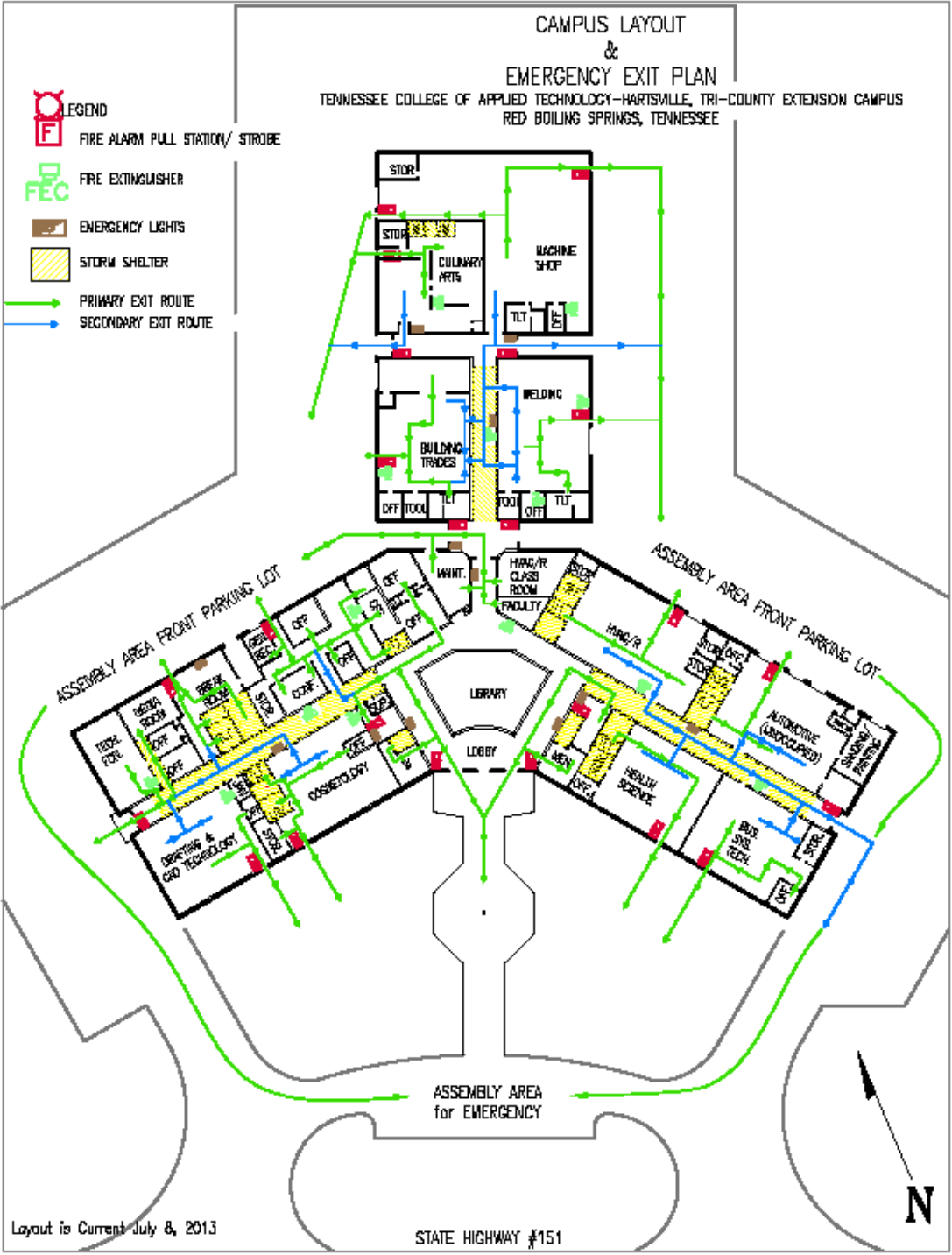

Wilson County Campus Emergency Exit Diagram

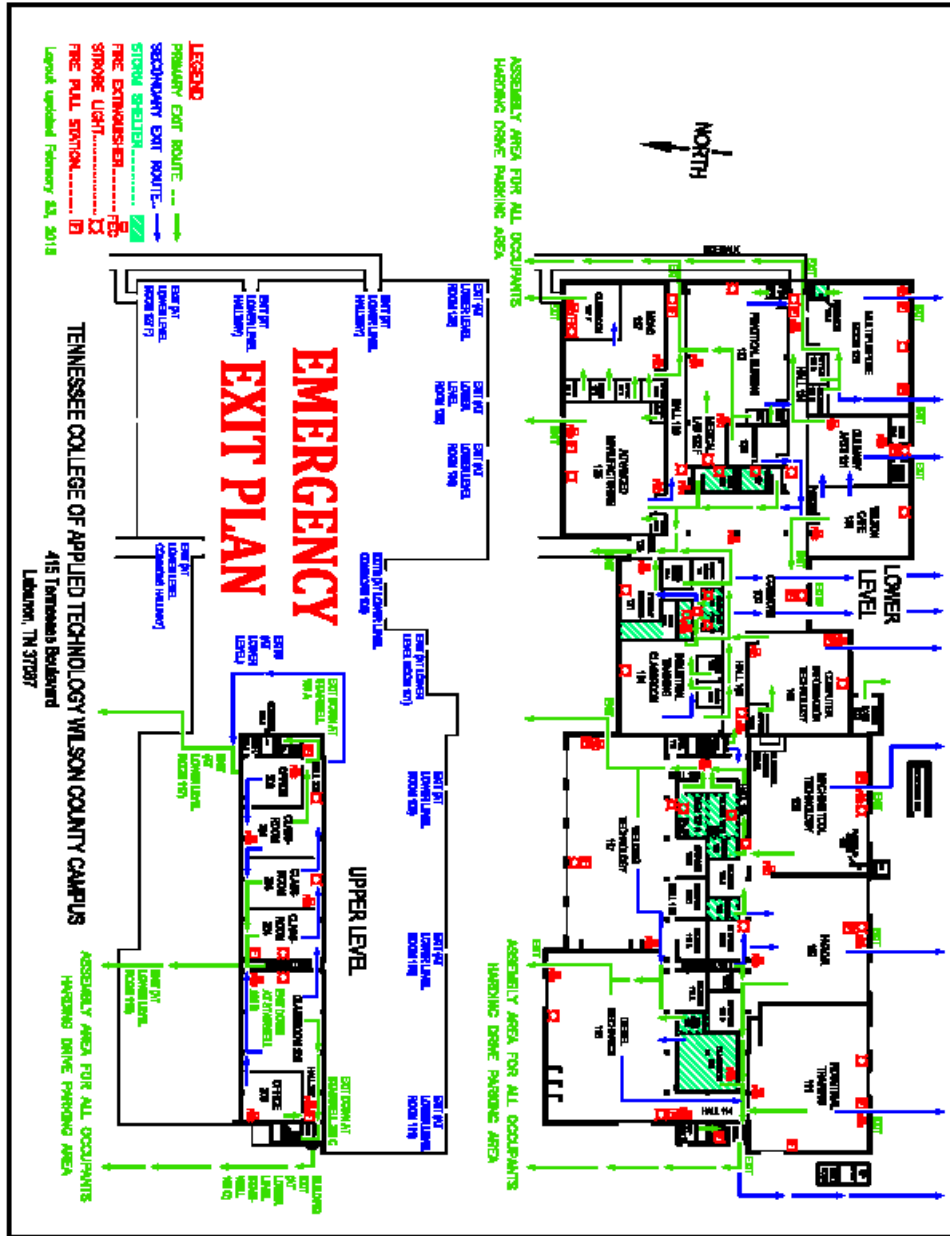

MEDICAL EMERGENCY

CODE **BLUE**

In the event that an accident or sudden illness of an employee, student or visitor takes place in your area:

ACTION TO TAKE

1. Notify your Instructor immediately, if the Instructor isn't available, notify Administration.
2. Give the following information, at least:
 - a. LOCATION of the emergency.
 - b. DETAILS available regarding the accident/emergency.
3. Try to keep the victim(s) comfortable and calm by reassuring them that help is on the way.

DON'T

DO NOT move, or allow an injured person to move, unless their location presents an additional hazard.

WHAT HAPPENS

1. Emergency personnel and the College's Allied Health department will be notified by the Administration or its designee.
2. A designated person shall wait on emergency services outside of the building to direct them to the most accessible route to the accident scene.
3. Basic First Aid will be provided by a trained individual, in accordance with Medical Emergencies Policy and Administrative Regulations.

Natural Disasters

CODE **BLACK**

TORNADO, EARTHQUAKES OR INCLEMENT WEATHER

A TORNADO WATCH is given when weather conditions are favorable to the formation of tornadoes. During a TORNADO WATCH, keep an eye on the weather and be prepared to take shelter immediately if conditions worsen.

A TORNADO WARNING is given when a tornado funnel is sighted or indicated by radar. You should take shelter immediately. That's why it is important to stay alert during severe storms. Be prepared to go to your assigned storm shelter area, (see your emergency exit plan's safe areas).

INCLEMENT WEATHER can lead to the above situation – use the same caution and procedures for safe areas.

ACTION TO TAKE:

1. Get away from the outer perimeter of the building and exterior glass.
2. Leave any exterior area and close the door behind you.
3. Go to your assigned storm shelter area (safe area).
4. Sit down and protect yourself by putting your head as close to your lap as possible, or kneel protecting your head, if space is available; if not, stand.

IF YOU ARE IN TRANSIT IN THE BUILDING:

5. Go to the nearest storm shelter area (safe area).
6. DO NOT go to the outside of the building.

IF YOU ARE IN AN OUTSIDE PERIMETER OFFICE AND UNABLE TO LEAVE THAT AREA:

7. Seek protection under a desk, and protect your head, face and neck from flying objects or broken glass.

IF YOU ARE OUTSIDE:

8. Lie flat in the nearest ditch, ravine or depression.

EARTHQUAKES

The actual movement of the earth, frightening as it is, seldom is a direct cause of death or injury. The earth's movement, however, can cause buildings and other structures to shake or collapse. Most casualties result from falling debris, splintering glass and fires. In the event that we should experience an earthquake, the following actions should be taken:

DURING THE EARTHQUAKE

1. Keep calm. Do not run or panic.
2. Stay where you are. Most injuries occur as people are entering or leaving buildings.
3. If the earthquake strikes when you are indoors, take cover under a desk, table, bench, or against inside walls or doorways. Move away from the outer perimeter of the building; stay away from glass, windows, and outside doors.
4. If the earthquake catches you outside, move away from buildings and utility wires. Once in the open, stay there until the shaking stops.
5. Do not run through or near buildings. The greatest danger from falling debris is just outside doorways and close to outer walls.
6. Douse all fires, without undue risk to yourself. Do not use candles, matches or other open flames during or after a tremor.
7. If you are in a moving vehicle, stop as quickly as safety permits, but stay in the vehicle. Avoid stopping near or under buildings, overpasses and utility wires. When you drive on, watch for hazards created by the earthquake, such as fallen objects, downed electrical lines, or broken or undermined roads.

AFTER AN EARTHQUAKE

1. Be aware of possible injuries to you or your fellow students.
2. Be prepared for additional earthquake shocks. Stay out of severely damaged buildings. Once it's safe to evacuate, evacuation will be announced.
3. Stay off the telephone except to report emergencies.
4. If you smell gas or observe electrical wiring shorting out, evacuate the building immediately and notify your Instructor (if your Instructor is unavailable, notify Administration.)

THUNDERSTORMS

1. Monitor weather conditions.
 - a. High winds and hail: if indoors, move away from the outer perimeter of the building; stay away from glass, windows, and outside doors. Stay near the innermost part of the building with cover nearby. If outdoors, with no shelter available, lie flat in a ditch and shield your head with your arms.
 - b. Lightning: Get inside as soon as possible, either a larger building or all-metal automobile. Do not use the telephone. If caught outside, do not stand underneath a tall isolated tree or a telephone pole. Avoid projecting above the surrounding landscape. If you should feel your hair "stand on end," drop to your knees and bend forward putting your hands on your knees. Do not lie flat. If outdoors, get inside a hard-top automobile and keep the windows up.

WINTER STORMS

1. Monitor weather conditions.
2. Be prepared for isolation.
3. Dress for the season.
4. Travel only if necessary.
 - a. Make sure your car is in good condition, properly serviced and equipped with good tires.
 - b. Travel with another person, if possible.
 - c. Make sure someone knows you are travelling and your approximate arrival time to your destination.
 - d. Carry emergency "winter storm" supplies in the car such as sand, shovel, windshield scraper, tow chain or rope, blanket, extra gasoline and a flashlight. Carry extra clothing such as gloves, hat, coat and etc.

FLOODING

1. Monitor weather conditions.
2. Stay alert. Prepare for evacuation as necessary:
 - a. Take only the essentials, i.e. car keys, credit cards, charged mobile phone and etc.
 - b. If it is impossible to evacuate, move to higher ground or a top level of the building, if available, and call for help.

3. Driving and Walking in Flood Conditions:
 - a. Call for emergency services to help.
 - b. Do not drive your car in floodwater.
 - c. Do not drive or walk in water that is even six (6) inches deep.

FIRE PROCEDURE

CODE **RED**

UPON DISCOVERY OF A FIRE:

1. Pull the nearest fire alarm, if the fire alarm has not sounded (fire alarm pull stations are shown on the emergency exit diagram). If possible, close the doors around the fire to contain it.
2. Notify your Instructor (if your instructor is unavailable, notify Administration) of the location of the fire and any other information available.
3. Building evacuation should begin as soon as the alarm is activated or evacuation notice is given (the alarm is intermittent for both the Hartsville campus and the Tri-County Extension Campus), whether automatically or manually. Follow your building's evacuation procedures.

DO'S

1. Use EXITS only.
2. Avoid inhaling fumes or smoke – if caught in heavy smoke; take short breaths, breathe through your nose and crawl close to the floor to escape. The air **IS** better near the floor.
3. Get clear of the building and wait in the parking lot for the “**ALL CLEAR**” notification from Administration or its designee.

DON'TS

1. DO NOT attempt to fight large fires.
2. DO NOT use elevators, when elevators are present.

WHAT HAPPENS

1. The Fire Department is notified by College personnel or through automatic response of sensors.
2. A designated staff person shall wait on emergency services outside of the building to direct them to the most accessible route to the fire.
3. **HELP IS ON THE WAY!**

BOMB THREAT

CODE **ORANGE**

IN THE EVENT A BOMB THREAT IS RECEIVED:

1. Emergency personnel and Administration are notified by the Switchboard Operator.
2. Building evacuation shall take place immediately; know your building's evacuation procedure.
3. A building search will be conducted by emergency personnel.
4. An "ALL CLEAR" signal will be given by Administration or its designee when authorized.

DO NOT TOUCH ANY SUSPICIOUS OBJECT, IF FOUND!

**HAZARDOUS MATERIALS, NATURAL GAS LEAK -
THREAT OF EXPLOSION**

CODE GREEN

HAZARDOUS MATERIAL EMERGENCY RESPONSE ACTION

The law requires that only those individuals who have been trained in Hazardous Materials Emergency Response may respond to a "HazMat" accident/emergency/spill.

IN THE EVENT A HAZARDOUS MATERIAL IS RELEASED IN YOUR AREA:

1. Notify your Instructor immediately (if your Instructor is unavailable, notify Administration).
Relay the following information:
 - a. Name and location of the material involved.
 - b. Approximate quantity and length of time of release.
 - c. If the release has been contained on site, or if the release has occurred into the air, drainage system or ground soils.
 - d. If any medical attention is needed.
2. Evacuate and isolate the area as soon as possible.
3. Avoid inhaling fumes, smoke, and/or vapors, even if hazardous materials are not involved.

IN THE EVENT OF A NATURAL GAS EMERGENCY:

1. Notify your Instructor immediately (if your Instructor is unavailable, notify Administration).
Relay the following information:
 - a. Location of the gas leak.
 - b. Details available regarding the gas leak.

2. Evacuate and isolate the area as soon as possible.
3. Remain as far away from the Building as possible.
4. Administration or its designee will give the “All Clear” signal when the emergency is over.

DON'T

1. DO NOT walk into or touch any spilled material.
2. DO NOT assume fumes, gases or vapors are harmless because of lack of smell.
3. DO NOT inhale fumes, smoke or vapors.

WHAT HAPPENS

1. Administration will notify emergency personnel if needed.
2. Designated staff will respond to the emergency.

VIOLENCE ON CAMPUS CODE **WHITE (LOCKDOWN)**

1. “Code White” is announced over the public address system.
2. Clear all open areas and go immediately to your training area.
3. Move to an area of the room away from windows and doors.
4. Instructors will lock all entrances into training areas. Staff locks all other areas.
5. All instructors and students are to remain in their training area.
6. Students WILL NOT be allowed to leave the training area.
7. DO NOT admit any one into training area unless cleared by Administration or its designee.
8. Maintain lockdown status until receiving the “All Clear” signal from Administration or its designee.

**IMPORTANT: DO NOT ATTEMPT TO INVESTIGATE ON YOUR OWN.
INTERFERENCE MAY HINDER THE SITUATION.**

SERIOUS OR VIOLENT CRIMES:

Gun or other Weapon

1. If a gun or other weapon is suspected in the classroom or other campus area, do not leave the room or area, but do try to ask someone to notify your Instructor (Administration if your Instructor is unavailable) immediately. Continue operating as usual until help arrives.
2. If a gun is pulled or displayed, do not attempt to disarm the person.
3. Remain calm and tell others to do so as well.
4. Stay away from the armed person and talk with him/her in a controlled manner. Use slow, non-threatening gestures, i.e., open palms. Avoid eye contact and adopt a submissive attitude. Do not crowd the person wielding the weapon, criticize him/her or argue with him/her.

Fights or Assaults

1. In case of a violent confrontation between two persons, do the following:
 - a. DO NOT attempt to physically stop a fight.
 - b. Have someone contact your Instructor (Administration if your Instructor is unavailable).

Hostage

1. Notify your Instructor (Administration if your Instructor is unavailable) immediately. Administration will contact the police. Remain calm and avoid quick movements. Use slow, non-threatening gestures, i.e., open palms. Avoid eye contact and adopt a submissive attitude. Do not crowd the hostage taker, criticize him/her or argue with him/her.
2. Follow all instructions of the hostage taker and tell all others to follow all instructions as well.
3. Do not attempt to disarm the hostage taker or negotiate with him/her.
4. Once police negotiators make contact, do exactly as they advise.

NUCLEAR ATTACK CODE YELLOW

1. Be aware of warning signals: bright, intense flash of light.
2. If you see a flash, take cover instantly. By getting inside or under something immediately, you could avoid being seriously burned. Never look directly at the flash.
3. Take cover in any kind of building, under a parked car or heavy piece of furniture. If no cover is available, simply lie down on the ground and curl up, cover your head with your arms and hands.
4. Move to a fallout shelter, where available, as soon as possible after the blast has been abated.

ELECTRICAL EMERGENCY CODE BROWN

How to Handle an Electric Shock

There are two classifications of electric shock: low voltage and high voltage.

Low voltage (household items)

1. Notify your Instructor immediately (if your Instructor is unavailable, notify Administration).
2. Determine if the person is still in contact with the circuit or power source. If the person is in contact, assume the circuit is still energized.
3. Never attempt to remove a person from an energized circuit with your bare hands!
4. Emergency personnel should assess the victim's medical situation.

High Voltage (outdoors or high voltage equipment)

If a person is in contact with a power line, assume the line to be energized and dangerous.

1. IMMEDIATELY notify your Instructor (if Instructor is unavailable, notify Administration) and/or 911.
2. DO NOT attempt to use an insulating device to free the person from the power line or equipment.
3. Stay clear and warn others to keep away (50 feet or more).

OTHER POTENTIAL EMERGENCIES

Emotional and/or Behavioral Disturbance

1. Present a calm appearance.
2. Listen to the person but do not accept verbal abuse. Say, "the way you are talking to me is not acceptable; I am willing to listen to your complaint as soon as you are willing to speak to me calmly and with respect."
3. If the person is getting too close, politely ask them to move back or turn your body so that you are not directly facing each other; keep at least five feet from the person. Do not argue with person, belittle or patronize him/her.
4. If you are comfortable doing so, reduce stimulation from the environment by walking the person to a quiet, but public area.
5. For immediate assistance, send someone to notify Administration.

Harassment: Racial or Sexual

1. General procedures for all physical, verbal and written harassment:
 - a. If you feel that you are in immediate danger, ask another person to stay with you, and then notify Administration.
 - b. Keep a journal of threats, (date, time, place and witnesses) and save any gifts, letters, and etc. Inform Administration.
 - c. Racial or sexual harassment must be reported to the Affirmative Action Officer.

Harassing email or voice mail

1. Do not delete the message.
2. Do not respond to the message since this action may only encourage further contact. Instead, save the email message to your computer or voice mail message to your telephone.
3. Print a copy of the email message with the header information included.
4. If the email originated on campus, contact Administration immediately. Off campus, contact the postmaster at the originating site (Internet Service Provider) along with Administration if associated with the Tennessee College of Applied Technology Hartsville.
5. Report all threatening emails and/or voice mails to the Affirmative Action Officer.

Stalking

1. Do not attempt to handle the situation alone.
2. Do not walk or ride alone.
3. Vary travel routes and daily habits.
4. Do not assume you are overreacting. Trust your instincts.
5. Report the incident to Administration.

6. Obtain a picture of the stalker if possible to be dispersed.

FIRE PROTECTION

A fire protection program must have the understanding and cooperation of every employee and student to be effective. Although the overall program is under the supervision of Administration, each employee and student should have direct interest in and responsibility for the fire protection program.

Everything necessary to start a fire is present in our training facility: fuel, such as gasoline; hydrogen generated during battery charging; packing and cleaning materials; paints and solvents; plastics, trash, and many other items; oxygen from the air, heat, produced in the form of flames or sparks; and electrical equipment.

Basically, fires produced by these elements can be prevented by maintaining a clean and orderly building. Scheduled maintenance checks of electrical machinery and ventilation systems and periodic facility inspections will provide additional safeguards to the fire prevention effort.

Fire - Safe Housekeeping/Prevention Tactics

1. Do not let trash and junk accumulate.
2. Don't string extension wires around.
3. Combustible materials should be present in work areas in only quantities required for the job and should be removed to a designated, safe storage area at the end of each work day. Never store combustibles near heaters or electrical outlets.
4. Never use gasoline, benzene, naphtha and/or similar fluids indoors. Never let oil or gas soaked rags accumulate in a closed space.
5. Never smoke or use a flame near combustibles.
6. Passageways, fire exits, and fire extinguishers will be kept clear and unobstructed.

Prevention is the best policy in regard to fire protection; however, in the event of a fire, the primary concern becomes safe evacuation of people from the scene of the fire. Because of this concern, all students and employees will be informed of the appropriate evacuation routes to be used in case of an emergency. Furthermore, fire drills will be conducted at trimester intervals to facilitate the orderly evacuation of personnel from the building.

Fire Training

1. Floor plans for the evacuation of the building will be posted in prominent places, with all students and campus personnel informed of fire extinguisher and fire alarm activator (fire pull station) locations.
2. Instructors will instruct students in regard to evacuation procedures along with fire prevention tactics.

FIRST AID – MEDICAL EMERGENCY POLICY

First aid is defined by the American National Red Cross as the "the immediate and temporary care given a victim of an accident or sudden illness until the services of a physician can be obtained." First aid is required whenever an injury occurs and should be limited to doing what is necessary to preserve life. The primary concern is the care of the injured person and prevention of additional injury to that person.

If a student is injured in the training area, the instructor will immediately initiate necessary basic first aid procedures by utilizing on-hand basic first aid supplies and notifying Administration. Administration will notify the Allied Health department. The Allied Health department will assess the medical situation further.

First Aid Supplies

A first aid kit with proper supplies will be maintained by each shop instructor. A regular inventory will be maintained and restocking kept up to date for disposable items.

Medicines/cleaners such as alcohol, methylate, first aid cream and etc., will not be kept to avoid misuse, expiration, or medicinal reactions. This rule also applies to the distribution of aspirin and common over-the-counter medicines; NO medication will be dispensed.

Primary Considerations

Primary considerations relate directly to the care and welfare of the injured student. The degree of care necessary would be determined by the seriousness of the injury. Certain basic steps are recommended for an injured student.

1. College personnel will attempt to ascertain how seriously the student is injured. Trained College personnel will provide assistance in injury care determination.
2. If medical assistance is needed, aid will be sent for immediately. Due to the location of the shops, the public address system, telephone, or other means may be used to alert Administration of the emergency. Administration will then place calls for assistance to the local ambulance/emergency medical services.
3. Trained College personnel will apply only that first aid which is essential and nothing further.
4. If a student is seriously injured, an ambulance will be summoned to transport the injured student the nearest medical facility, and every effort will be made to contact the student's emergency contact. Only after all other transportation possibilities have been exhausted, will College personnel transport the injured student to the nearest medical facility.

SAFETY PROCEDURES

Students may work in a training area only after they have successfully completed safety training for their applicable program area. All procedures performed in shops or classrooms must be consistent with the requirements of the approved health and safety plan.

SAFETY RULES

Safety rules are the means by which a person identifies the discretionary line between acceptable and unacceptable performance. Rules alone cannot be expected to influence attitudes among students. However, well prepared, illustrated rules can assist in making individuals aware of what is expected of them. It is important to remember that rules establish the minimum and maximum guidelines for behavior. The student must develop a thorough understanding of their purpose and be made to see how they, as individuals, can benefit by observing them.

Safety rules must be enforced and are a necessary part of an overall safety program. Because of our concern for the wellbeing of all individuals and the importance of rules to an overall safety program, any continuous or flagrant violation of these rules by students may result in termination from the College.

CARE AND MAINTENANCE OF PHYSICAL FACILITIES

Students have an obligation to implement proper housekeeping techniques. Shop materials and supplies should be stored in proper locations. Waste materials, tools, scrap, and grease on floors or workbenches and around machines should be removed regularly. Students should maintain daily cleaning and maintenance schedules with the end of the week's afternoon devoted to extensive cleaning and maintenance of the training area.

Maintenance personnel are normally scheduled to work when the buildings are open for use during normal daytime operating hours. While maintenance workers usually do not supervise the activities of students and instructors, they have definite authority to check any actions or activities which may decrease building safety.

A safe building, safe equipment, proper guards on machines, and adequate housekeeping practices are all factors which make for a safe, productive working environment.

Housekeeping

1. Adequate housekeeping practices are important factors in overall safety and fire protection.
 - a. The removal of rubbish and dirt eliminates many hazards.
 - b. Most fires start small. Removal of rubbish may aid in preventing the start of a fire or in retarding its spread.

- c. Keep floors free of oil, grease, or any other liquid. Clean up spilled liquids immediately; they are slipping hazards.
 - d. Aisles should be clear at all times to prevent tripping or other accidents.
 - e. Store materials in such a way that they cannot become hazardous.
 - f. Put tools away when not in use.
 - g. Place all scrap in scrap boxes.
 - h. Cleaning activities may bring into focus potential safety and fire hazards, thus encouraging elimination of the hazards.
2. Daily and periodic cleaning activities eliminate many existing and potential safety and fire hazards, thus encouraging elimination of the hazards.
 - a. Waste paper should not be permitted to accumulate. Waste baskets should be emptied daily.
 - b. Debris or rubbish within the training area should be removed.

Guards and Safety Barriers Can Protect Against or Prevent Injuries from These Sources:

1. Direct contact with exposed moving parts of a machine.
2. Work in process that may result in metal chips that fly from tools or abrasive wheels.
3. Machine failure which usually results from a lack of preventive maintenance, overloading, or abuse.
4. Electrical failure which may cause malfunctioning of the machine or cause electrical shock or burns.
5. Operator error or human failure caused by lack of knowledge or skill, distraction, fatigue or misunderstanding.

Positive prevention of injury-producing accidents on machinery can be assured through the installation of safeguards or through revision or design. Injury-producing accidents are inevitable where equipment with dangerous moving parts is operated without guards or with ineffective guards.

Code **BLUE**



Medical Emergency

ACTION TO TAKE

Notify Instruction and/or Administration

Code **BLACK**



Natural Disasters

ACTION TO TAKE

Take Cover; Evacuate only when instructed

Code **RED**



Fire Emergency

ACTION TO TAKE

Evacuate

Code **ORANGE**



Bomb Threat

ACTION TO TAKE

Evacuate

Code **GREEN**



Hazardous Materials, Natural Gas Leak – Threat of Explosion

ACTION TO TAKE

Notify Instructor and/or Administration; Evacuate area

Code **WHITE**



Violence on Campus - LOCKDOWN

ACTION TO TAKE

Lockdown procedures/Await for Instruction

Code **YELLOW**

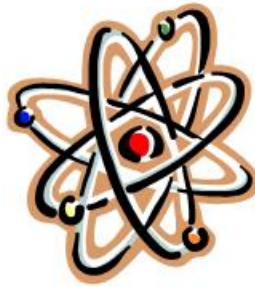

Nuclear Attack

ACTION TO TAKE

Take cover

Code **BROWN**



Electrical Emergency

ACTION TO TAKE

Notify Instructor and/or Administration; Evacuate area